

300lbs Electromagnetic Lock

300lbs EM locks were designed to meet fire/life safety applications by providing an auxiliary locking mechanism that has no moving parts to bind or wear out for trouble free operation. This will ensure inhibited release at all times where they have become extremely prevalent in applications other than fire/life safety. Suitable for access controlled & small enclosure.

- Life Safety Applications.
- Zero Residual Magnetism
- Low Energy Consumption
- Cost Savings
- 12/24Vdc Non-Selectable
- Ideal for all door types

Specification

Holding Force	Up to 300lbs
Magnet Size	170 X 35 X 23 mm
Armature Size	130 X 33 X 11 mm
Current Drain	300mA±10%/12Vdc, 150mA±10%/24Vdc
Operating Temperature	(-10 to 55)°C (14 to 131)°F
Housing Finishing	Anodized Aluminium
Weight	1.5kg

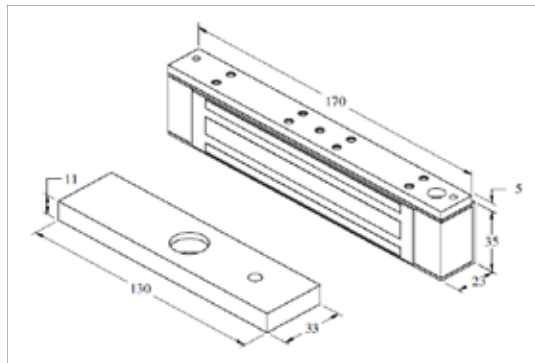

Standard Installation Diagram

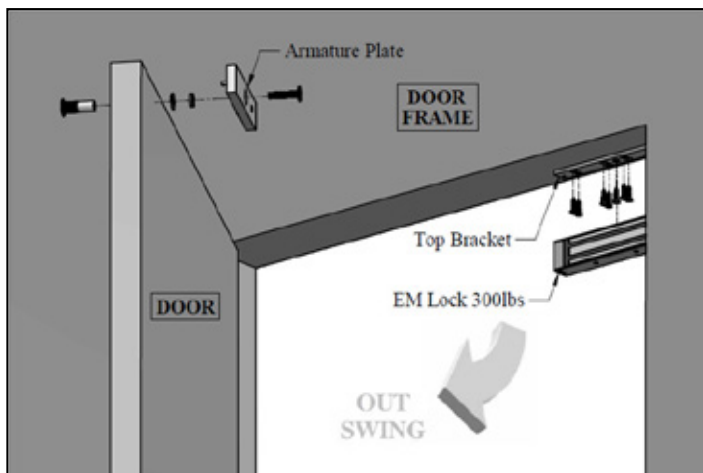

Explode View

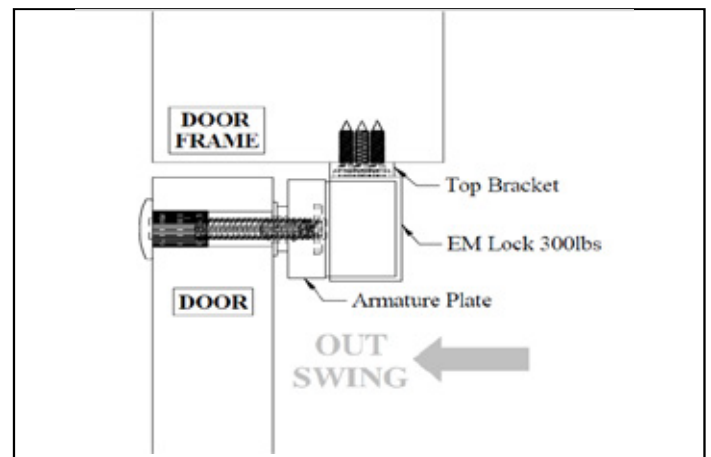

Side View

Head Office : D-162, Okhla Industrial Area Phase I, New Delhi, 110020.

Regional Office : Mumbai, Bengaluru, Ahmedabad, Chennai, Kolkata.

International Office : Dubai

Disclaimer : All pictures shown are for illustration purposes only. The actual product and color may vary due to product enhancement. The brief specification is mentioned and may change without prior notice. Please consult us before placing any order.

Phone : +91-95999-53923

Sales : sales@timewatchindia.com

Support : helpdesk@timewatchindia.com